

PlateRite 6600

Thermal Plate Recorders



Creating a Future in Print

A compact recorder that supports a wide variety of output formats and offers all the advantages of CtP



Versatile and easy to use

High cost-performance and better productivity

The PlateRite 6600 thermal plate recorder creates high-quality halftone dots. Simply choose the appropriate model for your productivity needs. The PlateRite 6600S features a 64-channel imaging head that can image up to 30 plates per hour* on the rapidly rotating drum. The PlateRite 6600E can output up to 18 plates per hour*. Both of these CtP units offer superior output quality and terrific cost performance.

* 724 x 615 mm, at 2,400 dpi.

Auto-balance for different plate sizes

Auto-balance lets you use different sized plates without making any manual adjustments for correct drum balance. All you do is select the type of plate you want to use and the PlateRite 6600 automatically makes the necessary adjustments to create perfect drum balance for each plate size. The PlateRite 6600 also features separate loading and unloading bays, so that one plate can be readied for loading while another is being exposed.

Get the ideal CtP environment with a simple upgrade

For the ideal environment for your increased productivity needs, you can upgrade your PlateRite 6600E so that it has the same productivity as the PlateRite 6600S, simply by exchanging a few parts. This simple upgrade reduces costs and improves the operational efficiency of your platesetter.

Support for a wide range of plate sizes

The PlateRite 6600 can handle the plate requirements of larger-format 4-page presses. It supports a maximum plate size of 980 x 685 mm (38.5" x 26.9") and is also capable of supporting some of the smaller 2-page presses with a minimum plate size of 304 x 370 mm (12" x 14.6"). The PlateRite 6600 offers an unbeatably flexible and reliable solution for fast output of a wide variety of plate sizes.

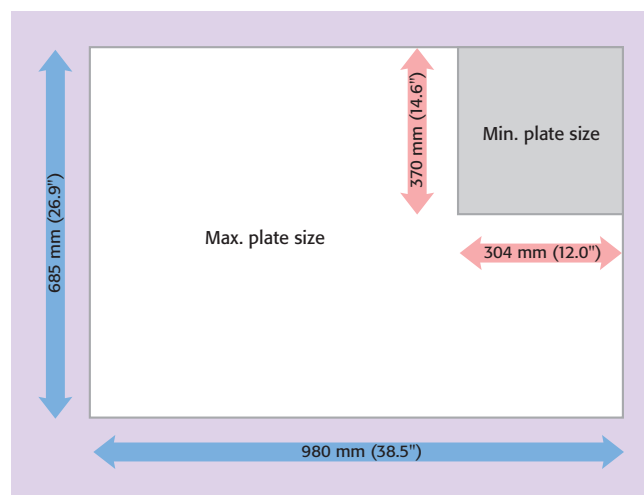

As demand for smaller printing lots and faster turnaround grows, it is increasingly important to ensure better operation ratios through the use of fully digital systems that can supply plates to the press in a timely manner, and that requires Computer to Plate (CtP).

Screen's PlateRite 6600 offers you all the benefits of CtP. They are compact plate recorders that are suitable for a wide range of plate formats for both web and offset presses, from B2 to A2-plus size. Equipped with original imaging and clamp technology from Screen, the PlateRite 6600 is easy to use and offer both high productivity and the flexibility to suit almost any workflow. The PlateRite 6600's combination of an advanced plate fixing system and plate auto-balancing makes it possible for the drum to rotate at a very high rate, which ensures superior production efficiency.

Productivity-enhancing automation

Automatic inline punch

Screen's automatic inline punching system is the industry leader for enabling perfect register on press. It does this by performing two types of punching (for press and platesetter registration) at the same time, immediately before mounting the plate on the drum. This method gives much greater registration accuracy compared with either manual or off-line punching, eliminates human error and achieves faster press makeready. Punch blocks from Heidelberg, Komori, Bacher, Protocol, Stoesser, Grapho Metronic and Screen are available, covering the full range of sizes for all major press types. Up to four punch blocks can be mounted and selected according to plate size and press type.

Autoloader options

The PlateRite 6600 can be configured for efficient automatic operation with Screen's optional autoloaders, which are acclaimed in the market for their reliability and precision. The PlateRite 6600 can be paired with the SA-L 6600 single-cassette autoloader. This high-quality unit can hold up to 100 plates and automatically removes interleaf paper before loading each plate. It is also possible to upgrade from the SA-L 6600 to the MA-L 6600 multi-cassette autoloader, which comes standard with three cassettes and enables up to 300 plates of three different sizes to be loaded and imaged in the PlateRite 6600 without operator intervention.

The PlateRite 6600 is supported by an automatic processor bridge, which extends the automation process all the way through to the plate processor.



SA-L 6600 single-cassette autoloader specifications

Plate transport	Fully automatic loading & automatic interleaf removal
Cassette capacity	100 plates
Dimensions (W x D x H)	1,550 x 1,750 x 1,070 mm (61.1" x 68.9" x 42.2")
Weight	Approx. 375 kg (825 lb)
Power	Powered by main unit



MA-L 6600 multi-cassette autoloader specifications

Plate transport	Fully automatic loading & automatic interleaf removal
Cassette capacity	100 plates per cassette
No. of cassettes	3 cassettes
Dimensions (W x D x H)	2,890 x 1,750 x 1,070 mm (113.8" x 68.9" x 42.2")
Weight	Approx. 800 kg (1,760 lb)
Power	Powered by main unit

Space requirements

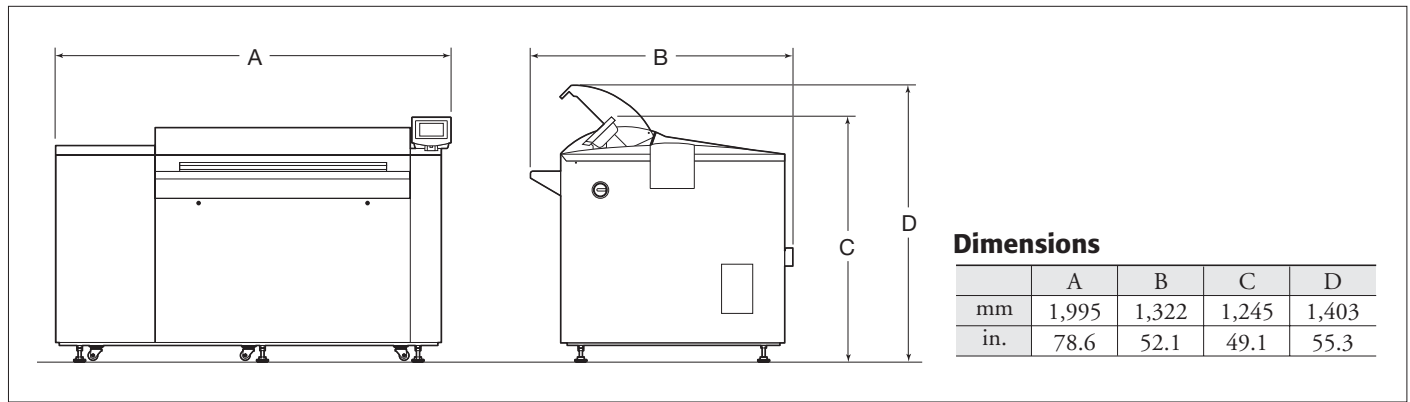

PlateRite 6600 specifications

Product name	PlateRite 6600S	PlateRite 6600E
Recording system	External drum	
Light source	64-channel infrared laser diodes	32-channel infrared laser diodes
Plate sizes	Maximum: 980 x 685 mm (38.5" x 26.9") Minimum: 304 x 370 mm (12" x 14.6")	
Exposure size	Maximum: 980 x 671 mm (38.5" x 26.4") [6-mm leading and trailing edges]	
Media	Thermal (infrared sensitive) plates	
Media thickness	0.15 to 0.3 mm (6 to 11.8 mil)	
Resolutions	1,200/2,400/2,438/2,540 dpi	
Mechanical repeatability	±5 microns*1	
Productivity*2	30 plates/hr at 2,400 dpi (724 x 615 mm/28.5" x 24.2")	18 plates/hr at 2,400 dpi (724 x 615 mm/28.5" x 24.2")*3
Interface	Fast PIF	
Plate transport	Semiautomatic loading or fully automatic loading,	
Dimensions (W x D x H)	Main unit: 1,995 x 1,322 x 1,245 mm (78.6" x 52.1" x 49.1") Blower unit: 600 x 429 x 361 mm (23.7" x 16.9" x 14.3")	
Weight	Main unit: 810 kg (1,782 lb); Blower unit: 25 kg (55 lb)	
Power requirements	Main unit: Single phase, 200 to 240 V, -10/+6%, 25 A, 5 kW (SA-L, MA-L, AT-T, and blower unit are powered by main unit)	
Environment	Recommended temperature: 21 to 25°C (69.8 to 77°F); Recommended relative humidity: 50 to 70% (no condensation) Required temperature: 18 to 26°C (64.4 to 78.7°F); Required relative humidity: 40 to 70% (no condensation)	
Options	SA-L 6600 single-cassette autoloader, MA-L 6600 multi-cassette automoader, built-in bridge, printing punches, signal tower unit	

*1 When exposing a single plate four consecutive times (temperature 23°C, relative humidity 60%).

*2 Productivity may vary depending upon media sensitivity.

*3 Users have the option of upgrading the PlateRite 6600E so that it has the same productivity as the PlateRite 6600S.

DAINIPPON SCREEN MFG. CO., LTD.

HEAD OFFICE

• Teranouchi-agaru 4-chome, Horikawa-dori, Kamigyo-ku, Kyoto, 602-8585 Japan/Phone +81-75-414-7610/Fax +81-75-414-7608

SCREEN (USA)

• 5110 Tollivaw Dr., Rolling Meadows, IL 60008, USA/Phone 847-870-7400/Fax 847-870-0149 www.screenusa.com

DAINIPPON SCREEN (DEUTSCHLAND) GmbH

• Mündelheimer Weg 39, 40472 Düsseldorf, Germany/Phone 0211-472701/Fax 0211-4727199/Telex 858-4438 DSDD D

DAINIPPON SCREEN (U.K.) LTD.

• Michigan Drive, Tongwell, Milton Keynes, Buckinghamshire MK15 8HT, UK/Phone 01908-848500/Fax 01908-848501 www.screen.co.uk

DAINIPPON SCREEN (NEDERLAND) BV

• Bouwerij 46, 1185 XX Amstelveen, Holland/Phone 020-4567800/Fax 020-4567805 www.screen europe.com

SCREEN FRANCE

• Z.I. Paris Nord II, 12 Rue des Chardonnerets, B.P. 50315, F-95940 ROISSY C.D.G. Cedex, France/Phone 1-48-17-86-00/Fax 1-48-17-86-01

DAINIPPON SCREEN SINGAPORE PTE. LTD.

• 29, Kaki Bukit View, Kaki Bukit Techpark II, Singapore 415963/Phone 67493833/Fax 67499010 www.screensp.com.sg

DAINIPPON SCREEN (CHINA) LTD.

• 6th Floor, 414 Kwun Tong Road, Kwun Tong, Kowloon, Hong Kong/Phone 2953-0038/Fax 2755-8683

Beijing office/Phone 010-6708-9271, 9272, 9273/Fax 010-6505-4975 (China)

Shanghai office/Phone 021-6466-4501/Fax 021-6466-4503 (China)

Guangzhou office/Phone 020-3891-1112/Fax 020-3891-1036 (China)

DAINIPPON SCREEN (TAIWAN) CO., LTD.

• 4F No. 126-1, Ming Tsai West Rd., Taipei, Taiwan/Phone 02-25862711/Fax 02-25914367

DAINIPPON SCREEN (KOREA) CO., LTD.

• 10th Yonsil Bongnae B/D 48-3, 1Ga, Bongnae-Dong, Joong-Gu, Seoul 100-161, Korea/Phone 02-7766-786/Fax 02-7766-787

DAINIPPON SCREEN (AUSTRALIA) PTY. LTD.

• Unit 2, 207-209 Young Street, Waterloo, NSW 2017, Australia/Phone 02-9310-1314/Fax 02-9310-3566

Internet web site : www.screen.co.jp

www.screenusa.com

www.screen europe.com

- This brochure was made using Spekta 2 screening.
- Printed on recycled paper.

We reserve the right to alter product design and specifications without prior notice.